

PARTS LIST						
ITEM	QTY	PART NO.	PART DESCRIPTION	LENGTH	UNIT WT.	NET WT.
1	2	X-CSRT-3048FW	CSRT FLANGE PIPE WELDMENT 2-7/8" x 48"		28.34	56.69
2	4	UNT10	UNISTRUT	120 in	20.38	81.52
3	8	UNICAP	UNISTRUT END CAP		0.03	0.26
4	4	X-UB1300	1/2 X 3" X 5" X 2" U-BOLT	5 in	0.74	2.95
5	8	G12LW	1/2" HDG LOCKWASHER	1/8 in	0.01	0.11
6	8	G12NUT	1/2" HDG HEAVY 2H HEX NUT	7/8 in	0.07	0.57
7	8	G38R-8	3/8" X 8" THREADED ROD (HDG.)		0.25	2.01
8	16	SQW38	3/8" SQUARE WASHER	2 in	0.29	4.63
9	16	G38LW	3/8" HDG LOCKWASHER		0.01	0.11
10	16	G38NUT	3/8" HDG HEAVY 2H HEX NUT		0.03	0.54
					TOTAL WT. #	149.38

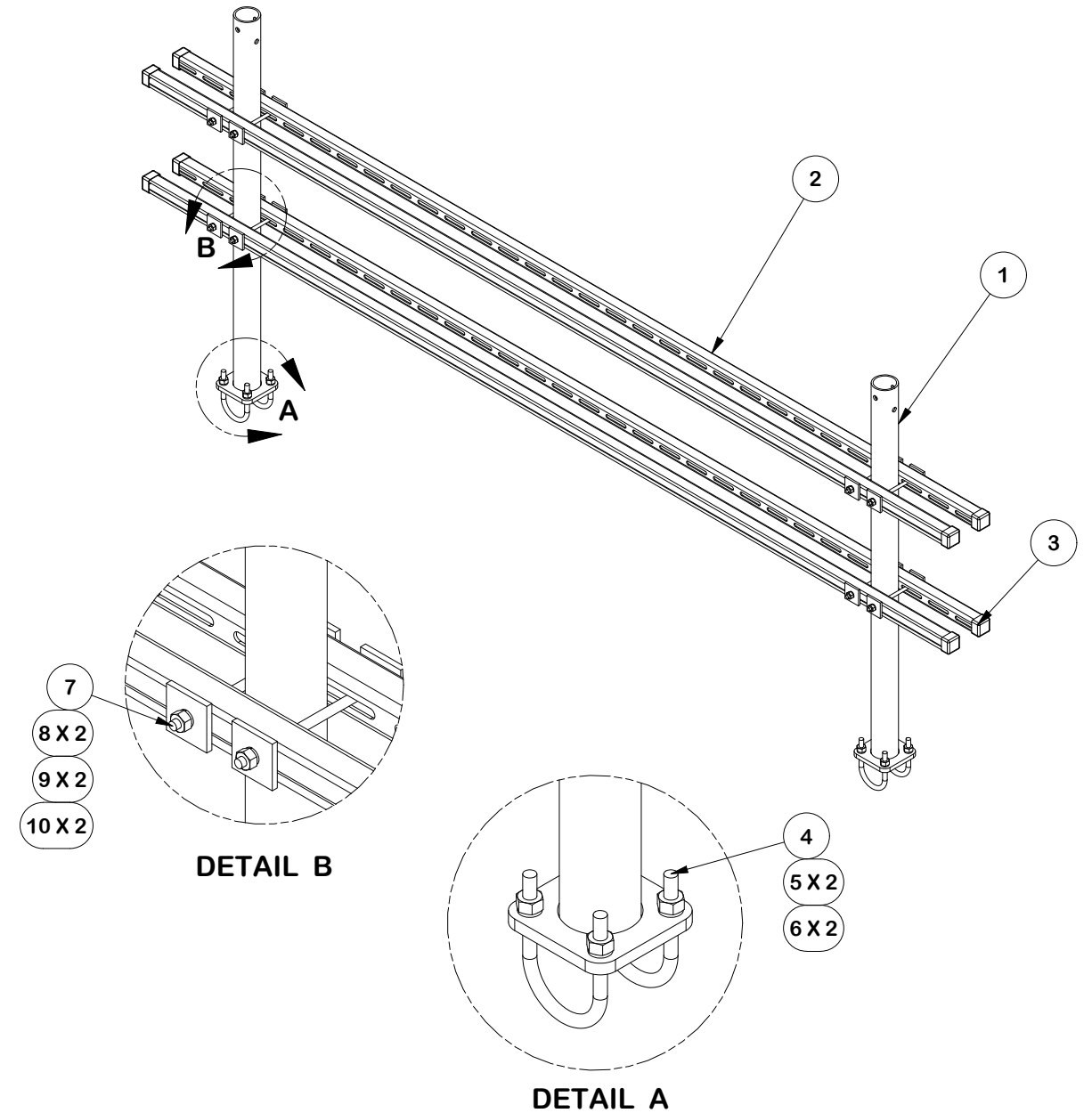
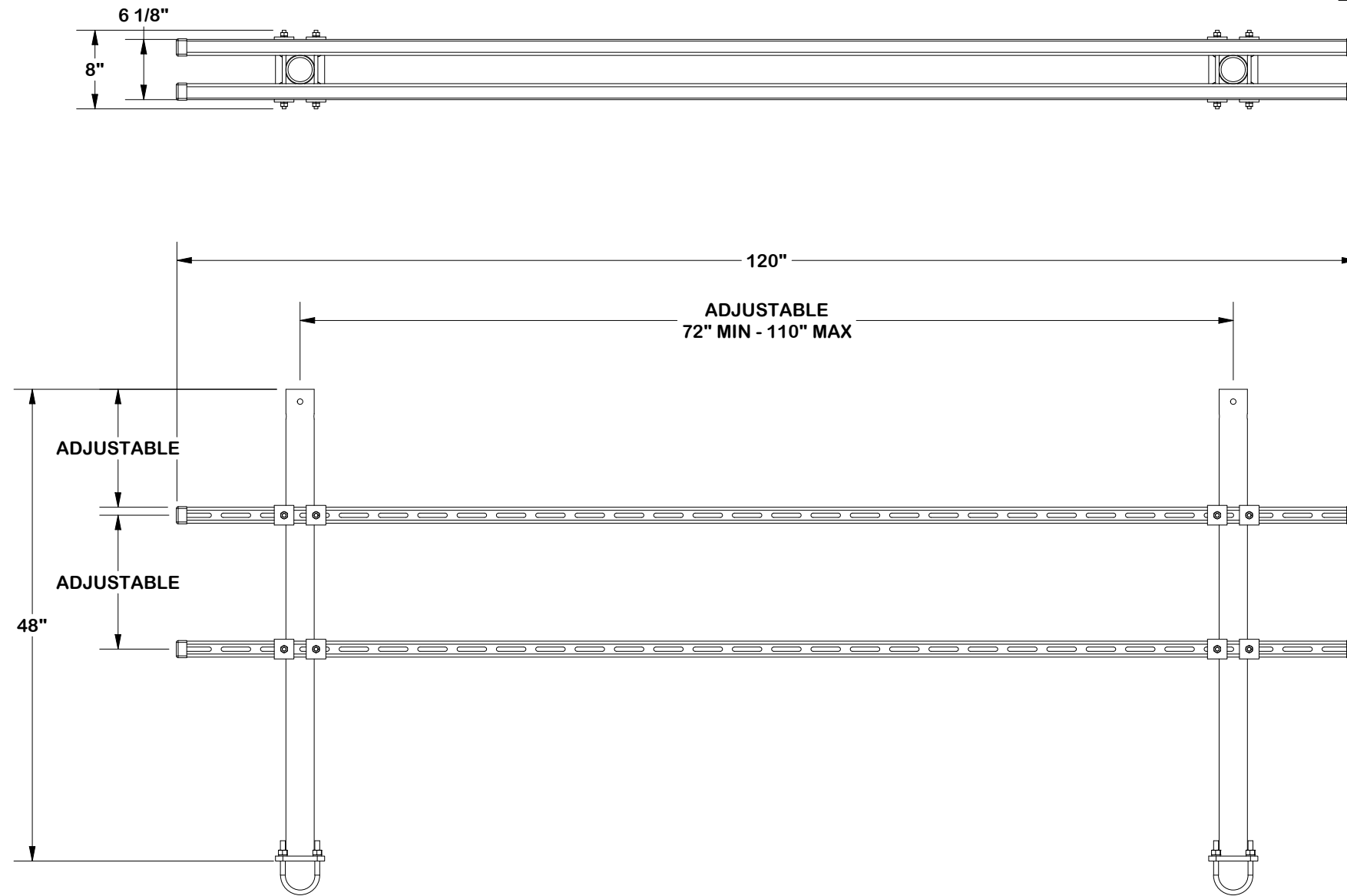

FINISH:
HOT DIP GALVANIZED.

TOLERANCE NOTES

TOLERANCES ON DIMENSIONS, UNLESS OTHERWISE NOTED ARE:
 SAWED, SHEARED AND GAS CUT EDGES ($\pm 0.030"$)
 DRILLED AND GAS CUT HOLES ($\pm 0.030"$) - NO CONING OF HOLES
 LASER CUT EDGES AND HOLES ($\pm 0.010"$) - NO CONING OF HOLES
 BENDS AND ANGLES ARE $\pm 1/2$ DEGREE
 ALL OTHER MACHINING ($\pm 0.030"$)
 ALL OTHER ASSEMBLY ($\pm 0.060"$)

PATENT INFORMATION: WWW.SITEPRO1.COM/PATENTS

PROPRIETARY NOTE:
 THE DATA AND TECHNIQUES CONTAINED IN THIS DRAWING ARE PROPRIETARY INFORMATION OF VALMONT INDUSTRIES AND CONSIDERED A TRADE SECRET. ANY USE OR DISCLOSURE WITHOUT THE CONSENT OF VALMONT INDUSTRIES IS STRICTLY PROHIBITED.

DESCRIPTION
**CONSTRUCTOR SERIES
 4' X 10' 2 LAYER RRU RACK**

CPD NO. SP1	DRAWN BY SDR 10/6/2025	ENG. APPROVAL 12/17/2025
CLASS 87	SUB 02	DRAWING USAGE CUSTOMER
	CHECKED BY JET 12/17/2025	



Engineering Support Team:
 sp1engineering@valmont.com

PART NO. CSRT-RRU2-410
DWG. NO. CSRT-RRU2-410